



Accessibility

EasyPlat, DomoStep and MiniPocket

Platform lifts for low and medium travel



MADE IN ITALY





Whether there are a few steps to overcome
or a height difference of a few metres,
AreaLift guarantees the ideal solution for every need.



AreaLift

Range of products for accessibility



DomoFlex



The DomoFlex platform lift is perfect for connecting floors both indoors and outdoors, such as lofts, penthouses, terraces, balconies and all those situations where the fixing points are limited
Maximum travel: **12 metres.**

See specific catalog

EasyPlat



Our lifting platform designed for overcoming architectural barriers. Ideal for two people standing or a wheelchair user and another person.
Maximum travel: **3 metres.**

Page 6

Arealift is the company specialised in the removal of architectural barriers, both in public and domestic premises. Our solutions have a smooth impact in your location thanks to the highly designed structures and to the glass surfaces. The whole range can be installed in a few hours or in a few days depending on the product type. All the products require reduced building work: we take care of everything!



DomoStep

The open platform, DomoStep 100A is the ideal solution to overcome architectural barriers **up to 1 metre**, in total safety. Designed specifically for people with reduced mobility or wheelchairs, alone or with another person.



Page 12

MiniPocket

It is the ideal solution to overcome a few steps in historical and architectural buildings. It offers almost no visual impact; when closed, the platform is hidden in the floor.



Page 16

EasyPlat

Lifting platform without shaft



Versatile solution

EasyPlat is the lifting platform solution for all environments: a house, a block of flats or any public buildings such as offices, shops or restaurants.

It guarantees full comfort and has been designed to overcome a small travel like a few steps or even an entire floor in complete safety up to 3 metres travel.

Why choose EasyPlat

- 🏠 Maximum level of safety
- 🏠 Take advantage of most of the available space
- 🏠 Extremely quiet
- 🏠 Easy maintenance
- 🏠 Quick installation time: maximum 1 day
- 🏠 Italian style, with sophisticated design, LED strips and double control panels
- 🏠 Absence of building works (no pit needed)
- 🏠 Minimal aesthetic impact
- 🏠 Can be installed both outdoor and indoor
- 🏠 Made in Parma, Italy



Outdoor



Indoor



Suggested
use



Max payload
400 Kg



230 VAC
Single-phase



Stylish for the home

EasyPlat has been designed to fit all environments including domestic properties.

The EasyPlat **neat design offers unique details** thanks to the stylishly shaped profiles, lighting with LED strips and large glass panels.

Simple, thanks to the absence of building works

EasyPlat simply stands on the floor.

It has an integrated ramp for access and egress and it does not require a pit.

Load-bearing walls are not required.

EasyPlat requires minimal space, it does not require a machine room or any external cabinet.

EasyPlat



Perfect for a block of flats

EasyPlat can be installed in a block of flats to help everyone overcome small travels.



EasyPlat is activated by pressing a button, both on the platform and at the arrival floor. It is equipped with **double control panels on both sides**. The column or the wall-mounted push-button panel, both with wireless buttons, can be positioned to suit.



Functional in any public environment

EasyPlat is the ideal solution to overcome architectural barriers in public environments. It will ensure easy access for everyone in schools, shops, restaurants and offices.



LED lighting, improves the design of the product and helps to visualise its overall dimensions in the dark ensuring higher safety.

Quick and easy to install

EasyPlat can be installed in a short time:
less than one day!

The main components are pre-assembled supplied to simplify and speed up the installation process.

The possibility of adjusting the travel +/- 50 mm on site avoids small and annoying steps that you can find between the platforms and the finished floor.

EasyPlat

Finishes

Lift guides and guide infill panel

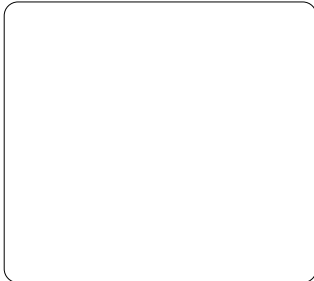

Anodized aluminium
Standard

Platform painting

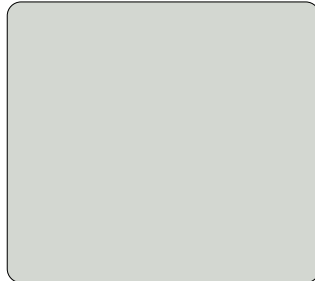

RAL 7035 - Light grey
Standard

Glass



Natural
Standard

Smoke Grey
Optional

RAL painting | AreaLift range - Optional for platform and / or guide infill panel



Floors



13772 - PVC "Eternal Collection"
Eternal Brushed Aluminium

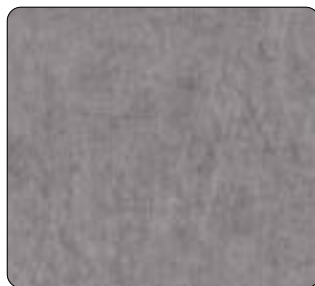

13712 - PVC "Eternal Collection"
Eternal Brushed Chrome

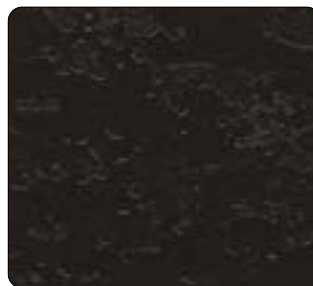

42292 - PVC "Eternal Collection"
Eternal Charcoal Slate



Aluminium
5 bar aluminium tread plate

COP and buttons



- 🏠 54 x 54 mm control buttons with embossed decoration
- 🏠 Matt steel colour finish
- 🏠 Blue backlight
- 🏠 IP54 rated protection

EasyPlat

Technical specifications

Travel	Max 3000 mm Min. 600 mm
Installation adjustment	+/- 50 mm
Load	400 kg
Stops	2 Max
Entrances	Front and rear only
Controls	Hold-to-run button
Installation	Indoor or outdoor
Platform dimensions (L1xL2)	1100 x 1400 mm 900 x 1400 mm 900 x 1250 mm
Minimum headroom required	1600 mm
Pit depth	Not required: integrated ramp Floor height: 70 mm
Drive	Electromechanical motor with belt
Operation	Push button
Remote Control	2 pieces kit (standard)
Maximum speed	Max 0.10 m/sec (6 m/min)
Cycles/hour	10 max
Temperatures range	-5°C / + 40°C
Noise	less than 30 dB
Power supply	Single-phase 230 Vac - 50-60 Hz
Installed power	1.1 kW
Max. Absorption	16 A
Drive systems	On-board at upper level
Control systems	On-board
Reference standard	CE Mark - In compliance to BS6440-2011 and D.M. 2006/42/CE

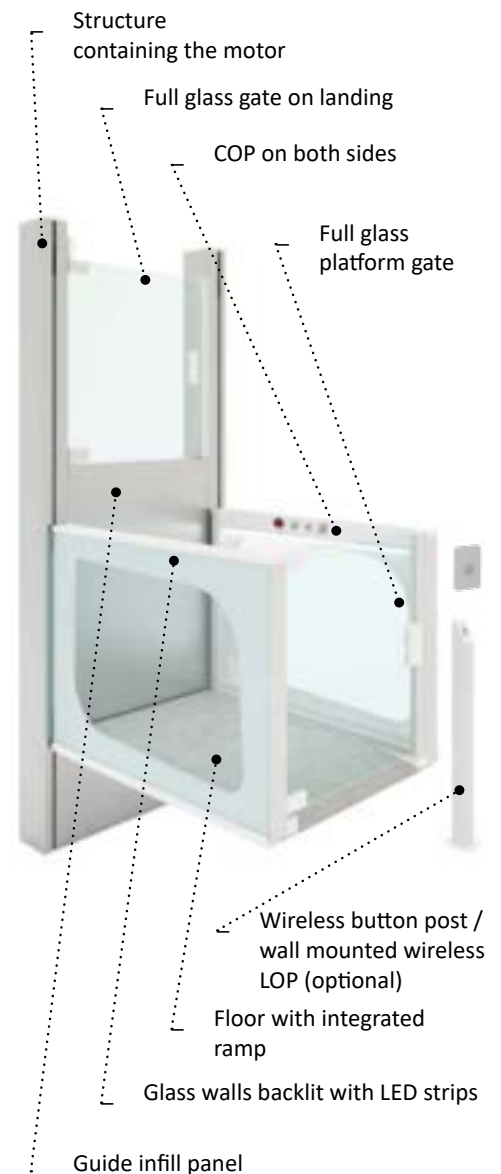

Dimensions

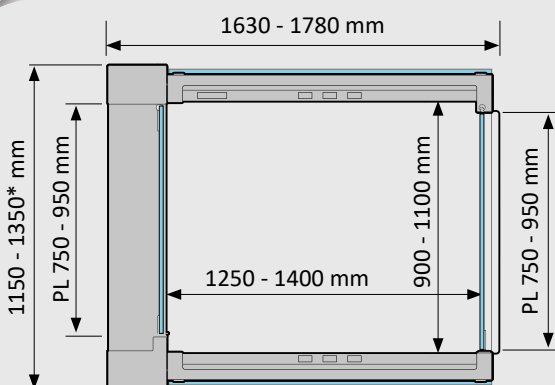

* Allow at least 400 mm of free space on both sides for maintenance

Safeties

- 🔒 Anti-crushing sensitive bottom under the platform
- 🔒 Front side anti-shearing wall
- 🔒 Safety gear
- 🔒 Overload and belt loosening sensor
- 🔒 Electric lock locking control
- 🔒 Automatic emergency descent operated on board with UPS system in case of power outage
- 🔒 STOP button for emergency stop
- 🔒 Acoustic ALARM button on board
- 🔒 Emergency light
- 🔒 Disabling key ON / OFF at upper level
- 🔒 Autodialler (optional)
- 🔒 Motion buzzer (optional)

DomoStep 100A

Open platform without wall fixings



Versatile solution

DomoStep 100A is the ideal solution to overcome architectural barriers **up to one metre in complete safety**. It is designed for people with reduced mobility and using a wheelchair, with or without an accompanying person.

Safety, versatility and reliability, reduced overall dimensions and quick installation are DomoStep 100A strengths.

The platform, in compliance with Machinery Directive 2006-42-CE, does not need any building work; it is battery-powered and does not require any fixed wiring. A standard socket is enough.





Suggested use



Max payload



Stand-By power consumption



In-use power consumption



DomoStep 100A

Finishes

Steel structure painting

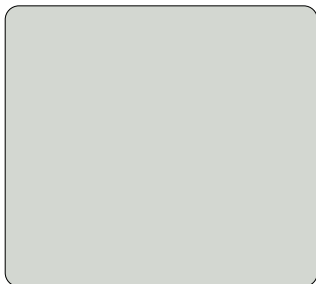

RAL 7035
Light grey - **Standard**



RAL Painting
AreaLift range

Floors



Aluminium - 5 bar aluminium
tread plate - **Standard**



N004
Black round studded rubber

Configuration

Safety

- Emergency STOP
- Lowering to landing in case of power outage
- Lower sensitive underpan (without bellows)
- Battery powered

Platform operating panel

- Standard with n° 5 buttons

Wireless operating panel (kit 2 pieces)

- N° 1 button
- N° 1 hold-to-run key
- N° 1 button + 1 key switch 2P/2E

Landing gate

- BL Blank (painted RAL 7035 Light Grey)
- BL Blank (painted RAL in AreaLift range)
- GL Glazed
- Powered gate opening system

- Standard Optional

Protection bellow (in compliance with the current directive)

- 85 mm pit

Protection bar and handlebars

- side fixed handlebar
- Automatic fall-prevent bar

Finishes (balustrade, anti-shearing wall, platform, column and accessories)

- BL Blank (painted RAL 7035 Light Grey)
- BL Blank (painted RAL in AreaLift range)

Platform

- Customised dimensions (within max limits)
- 5 Bar Aluminium tread plate floor
- Round Studded Rubber black floor

Extra version

- OUTDOOR - AISI 316 stainless steel
- OUTDOOR - Electric and Mechanical protection

Dimensions

STANDARD VERSION

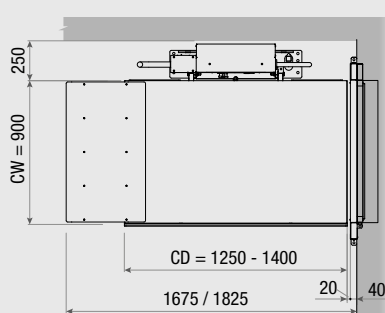
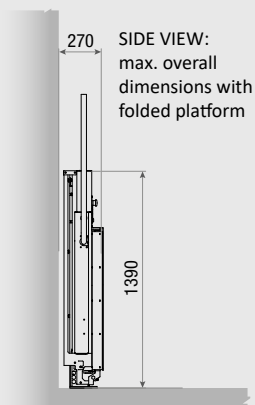

TOP VIEW: max overall dimensions
with unfolded platform

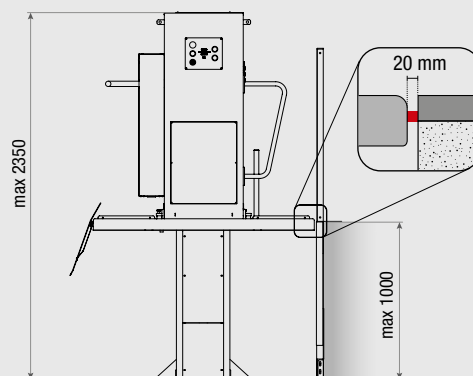

FRONT VIEW:
overall height at max extension

Technical specifications

Maximum travel (H max)	1000 mm
Drive	Hydraulic
Operation	Hold to Run
Speed	0.05 m/s (5 cm per second)
Power supply	Single-phase 230 Vac
Stand-by power consumption	6 W (electrical network supply)
In-use power consumption	46W (electrical network supply)
Cycles /hour	Max 10 (with 250 kg load)
Temperatures range	-5°C / + 40°C
Batteries	2 x 12Vdc 7Ah
Power Unit	Embedded in the column
Platform	Manually foldable (version without balaustrade)
Platform dimensions (L1xL2)*	900x1250 - 900x1400 mm
Remote control	Included (2 pcs)
Fixing (travel ≤ 0.5 m)	Floor fixing
Fixing (travel ≤ 1.0 m)	Floor and wall fixings
Packaging	Wooden box

* Customized dimensions (on demand)

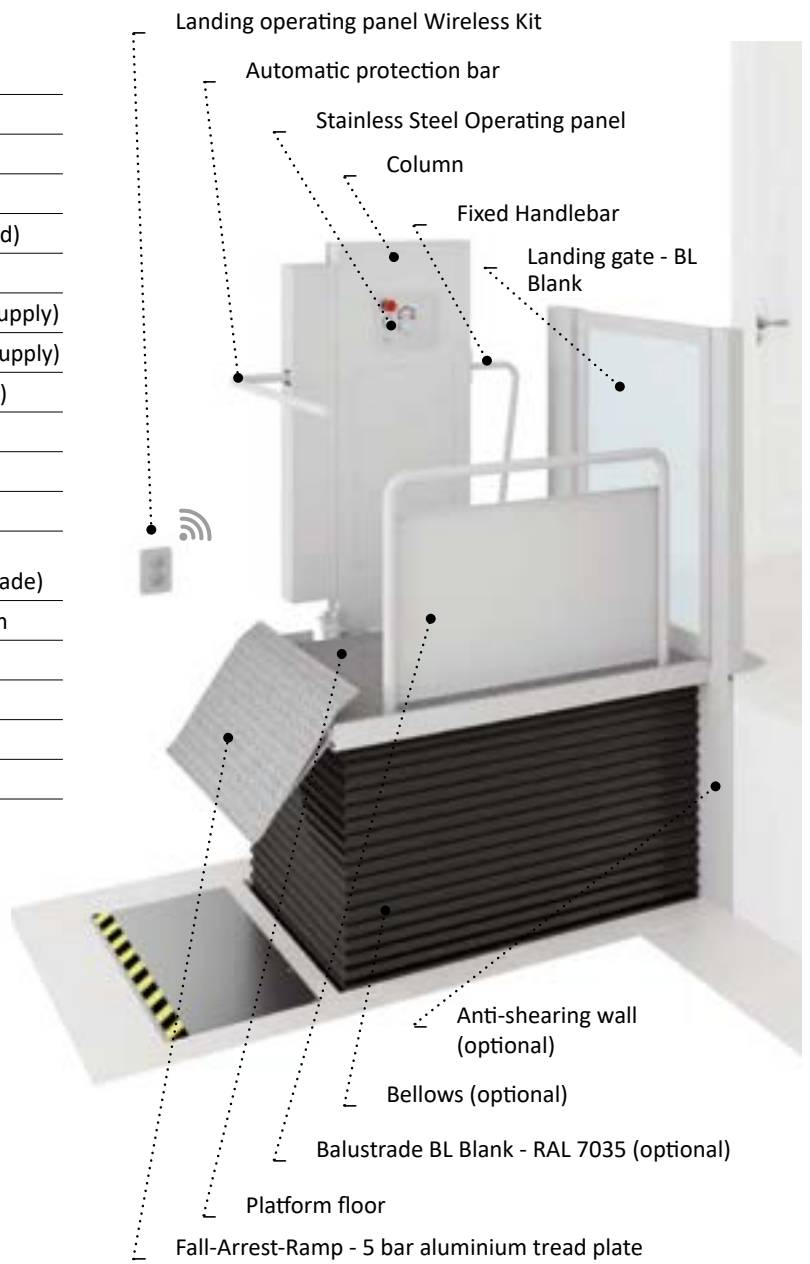
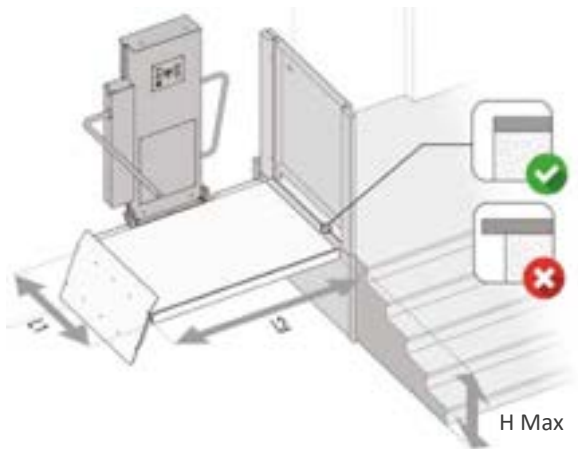

BELLOWS VERSION (OPTIONAL)

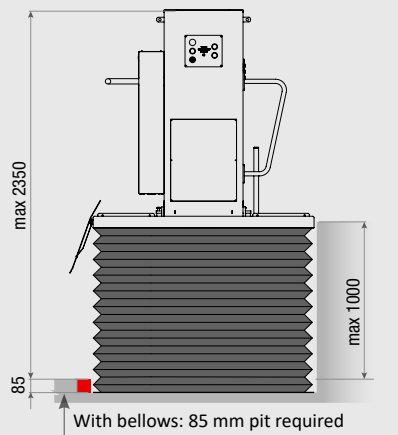
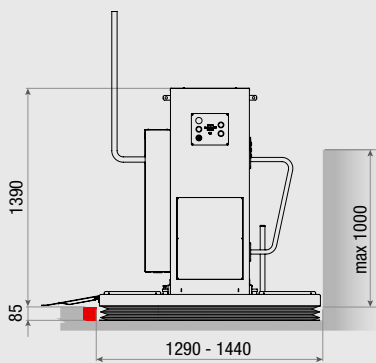

MiniPocket

Scissor platform with combined vertical and horizontal movement



Perfectly integrated

It's the ideal solution to overcome a few steps wherever special architectural commitments are required. Its visual impact is almost insignificant since the platform is embedded in the floor when closed.

Thanks to its constructive features MiniPocket platform makes it possible to use the same flooring of the installation site. Once closed, the platform becomes invisible.

Public and private use

Suitable for public and private use to overcome architectural barriers.

Outdoor installation

It can be used outdoor since all material is IP54 rated.



Safe and comfortable

MiniPocket platform is designed for users with reduced mobility, with or without a wheelchair, and it's equipped with a safety system that ensures its reliability.

Hydraulic scissor platform

Hydraulic scissor technology allows the production of embedded platforms with high payloads and reduced dimensions. Additionally they offer the reliability and safety of hydraulic operation.

MiniPocket

Finishes

Steel structure painting

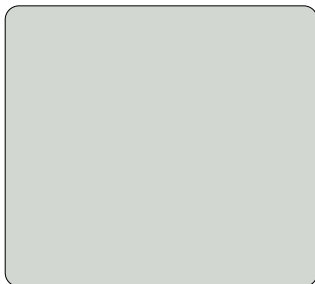

RAL 7035
Light grey - **Standard**



RAL Painting
AreaLift range

Floors



Aluminium - 5 bar aluminium
tread plate - **Standard**

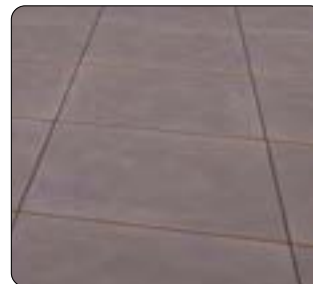

Floor provided by customer
Max. thickness 30 mm

Platform column



Scotch Brite
Stainless Steel



Configuration

Platform floor

- Anti-slip aluminium
- Floor provided by the customer - 30 mm max thickness
(max. 60kg/mq)

Gate for travels > 500 mm

- BL Blank painted (RAL 7035 Light grey)
- BL Blank painted (RAL AreaLift range)
- GL Glazed
- Gate motor

Column

- Platform column without fall protection bar
- Platform column with fall protection bar (travels < 500 mm)
- Platform column with fall protection bar (travels > 500 mm)
- Landing column kit for remote controls

Safety systems

- Black out emergency descent
- Front sensitive edge on the landing access
- Black PVC bellows (on 3 sides)
- Aluminum retractable automatic protection edges on three sides (excluding access side)
- Emergency buttons (STOP and ALARM)
- Low tension control circuits

Accessories / options

- Platform enabling key switch
- Wireless landing push button kit (2 pcs.)
- Additional remote control

Standard Optional

MiniPocket

Technical specifications

Max travel	780 mm (H max)
Max horizontal movement	800 mm (T max)
Platform dimensions (L1xL2)	950x1540 mm (std) or 1100x1540 mm (opt)
Pit dimensions	1025x1590 (std) or 1175x1590 mm (opt)
Pit depth	220 mm ^(A)
Drive	Hydraulic scissor
Operation	Hold to run
Remote control	2 pcs. Included
Max speed	0.05 m/s (5 cm per second)
Cycles per hour	10 max
Power supply	230 Vac single-phase
Rated power	370 W
Max electrical absorption	2 A
Control panel	In separate box
Hydraulic system	In the pit
Reference Standard	Machinery Directive 2006/42/CE

(A) If the floor is provided by the customer, please add 30 mm (max 60 kg / sqm)

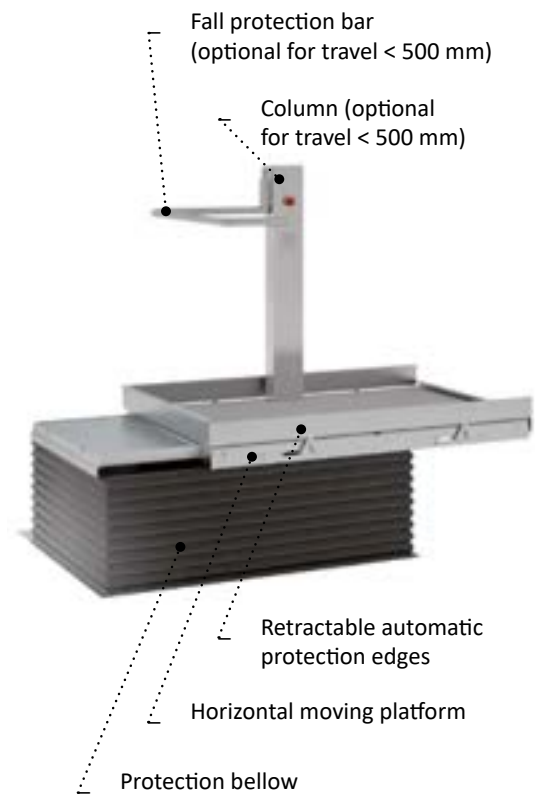

Dimensions

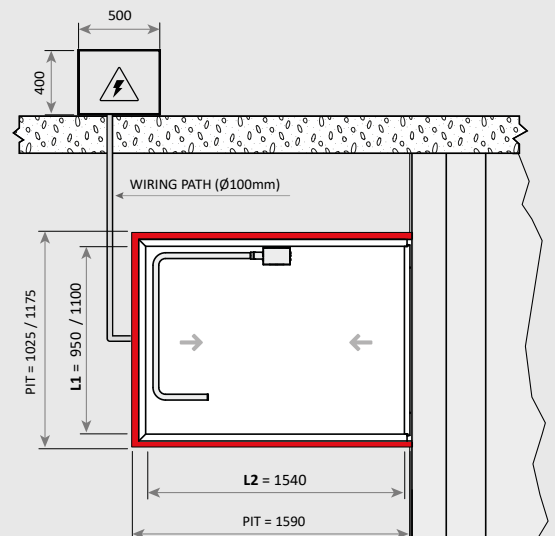
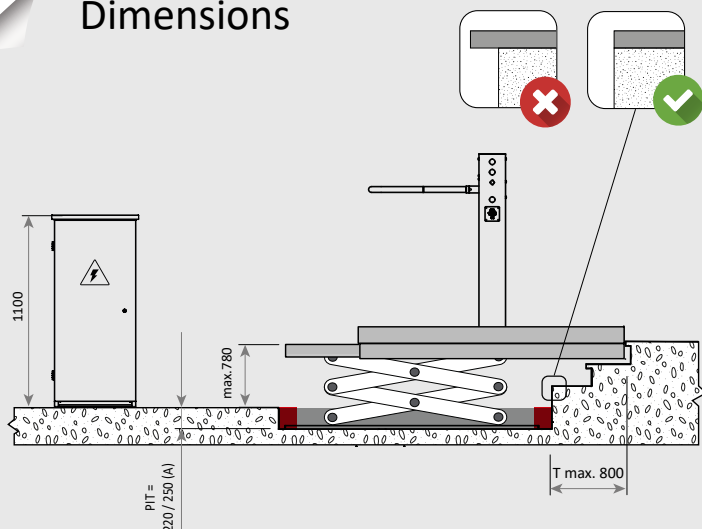

Who we are

Arealift is a young company established by professionals with long experience in the vertical transport sector.

Arealift is specialised in the design and production of home and platform lifts to overcome differences in height up to 12 metres.

Our products are sold in over 30 countries worldwide!

Made in Italy

What makes us unique is the Italian style and the attention to quality which comes from our history as a manufacturing company.

Functional and comfortable, Arealift's lifting platforms allow the user to move easily, in perfect autonomy and with the charm that distinguishes the Italian style.

LiftingItalia and AreaLift

The group consists of two young and dynamic companies that work in perfect synergy complementing each other.

LiftingItalia - Established in 2003, is the parent company and today is specialised in the production of **high quality homelifts**.

AreaLift - Established in 2006, is a company **specialised in accessibility solutions and vertical mobility**.



AREALIFT S.r.l.

Via Caduti del Lavoro, 22
43058 Bogolese di Sorbolo - Parma, Italy
Tel. +39 0521 695311

www.arelift.com



Authorized reseller